



1.2" LED display



Wireless Remote Control

CASTON-II SERIES

Crane Scale

CASTON-II is a rugged heavy-duty hanging scale for various industrial environments. The series is applicable in industrial areas including manufacturing factories and also heavy-duty industrial plants. Equipped with a wireless remote control function which makes operation more efficient and safe.

- Trade approved (NMI No. 6/13/4)



CASTON-II SERIES | Crane Scale

SPECIFICATIONS

Model	2THB	3THB	5THB
Max. Capacity (kg)	2,000	3,000	5,000
Readability (kg)	1	1	2
External Resolution	1/2,000	1/3,000	1/2,500
Display Digit	5 Digits		
Display Type	LED (1.2 inch)		
Operating Temp.	-10°C~40°C		
Power	DC 12V		
Dimensions (mm)	230(W) x 370(D) x 474(H)		230(W)x 370(D) x 518(H)
Product Weight (kg)	17		20

FEATURES

- Standard wireless remote controller
- 2x Rechargeable battery packs & charger included
- Battery operated with low battery indication
- on/off, zero, tare, and hold function
- Easy-to-read 1.2" LED display
- Auto span adjustment & zero tracking

DISPLAY & KEY PAD

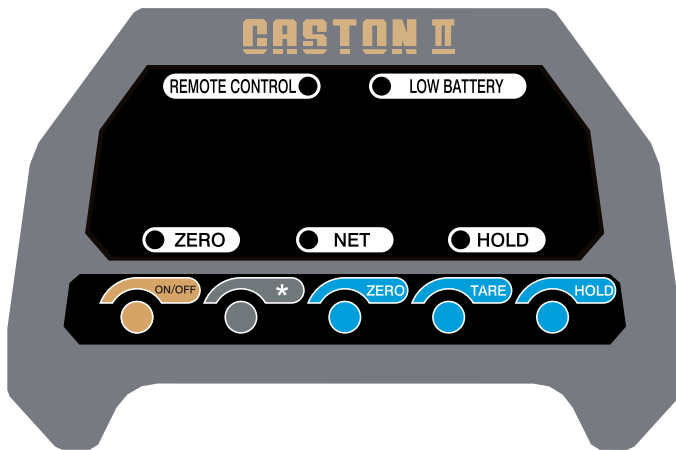

DIMENSIONS

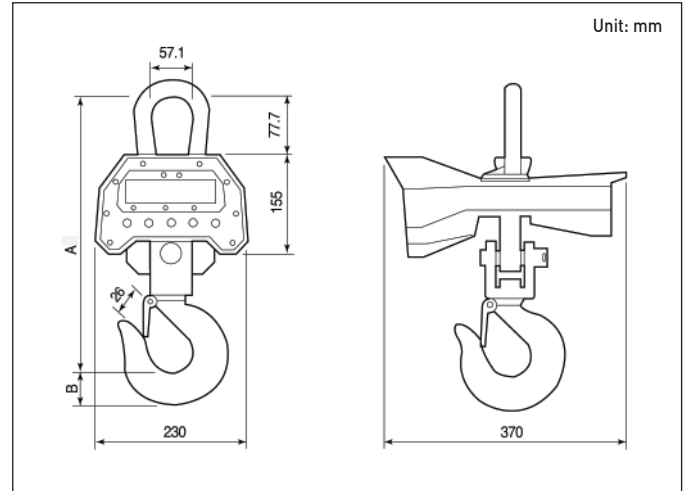

Model	A	B
2 THB	430	44.5
3 THB	430	44.5
5 THB	474	44.5



UNIT 8, NORTHLINK, 459 TUFNELL ROAD
 BANYO QLD 4014, AUSTRALIA
 TEL_ +61 7 3267 7767 FAX_ +61 7 3267 1818
 EMAIL_ sales@cassscale.com.au
www.cassscale.com.au

Specifications are subject to change for improvement without prior notice.



Proudly Sold & Serviced By:
Able Scale Co Pty Ltd
 Ph: 1300 731 360
 21 Green St Thomastown VIC. 3074

find us on the web: www.ablescale.com.au